



ANCHOR GATE SYSTEMS



- Swing Gates • Overhead Slide Gates
- Cantilever Slide Gates • Vertical Lift Gates



First Because They Last.™

The Better Way To Build Your Cantilever Slide Gates...

The Principle of the Exclusive Anchor Cantilever Slide Gate

“More than 30 years ago, Anchor’s engineering team developed the Enclosed Track/Internal Roller Cantilever Slide Gate. This advance in technology was a significant accomplishment; one that was far ahead of its time.

Today, companies with little or no engineering experience attempt to copy Anchor’s distinctive enclosed track system. However, they’re really unknowing of what makes the Anchor gate work so precisely...time-after-time, year-after-year.

Don’t be taken in by unproven look alike.

Demand a Genuine Anchor Gate. It will work right every time.

The distance between gate posts determines the reference size of a cantilever gate. For example, a 20 foot (6.1m) opening takes a 20 foot gate. However, to use the cantilever principle, an extra section (overhang) must be included to provide the necessary support when the gate is in the closed position.

This additional section, containing no chain link fabric, requires that the corresponding footage along the fence line

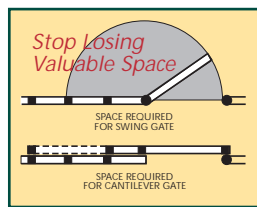

must be available to allow the gate to open fully. Anchor’s extra section,

however, is shorter than the overhang of any other free hanging gate.

One roller bearing truck assembly is mounted on the

post which supports the gate. A second roller bearing is mounted on the overhang post. This post is placed at a specified distance down the fence line, and varies with the size of the overhang which, in turn, changes with the size of the gate.

The track section of the top frame member of the gate slides over both these truck assemblies. The gate is adjusted for proper operation, and stops are installed to end the gate’s movement at the exact required positions.

The weight of the gate is always efficiently distributed, depending upon the position of the gate. The ball bearing truck assemblies sometimes bear against the top part of the track, and at other positions, the truck assemblies bear against the bottom part of the track.

With this exclusive Anchor design, no wheels or supports are needed on the bottom of the gate. Guides are placed only on the bottom of the posts to keep the gate from swinging.

Anchor’s Cantilever Slide Gates can pass over any surface. This is an outstanding benefit when it is necessary to pass the gate over unpaved or uneven driveways, railroad tracks, water, etc.

Anchor’s procedure for attaching the fabric to the frame not only provides more security, it also aids in stiffening the gate frame.

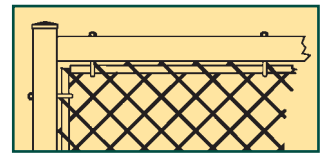

The fabric is held inside the frame by tension rods and hook bolts that pass through the frame on all four sides. These bolts are mechanically tightened to give the fabric a drum like tightness. Each strand of fabric wire becomes a truss that helps support the frame. This is superior to simply hanging the fabric on the frame as others do.

Anchor Cantilever Slide Gates: An Inside Look at How They Work

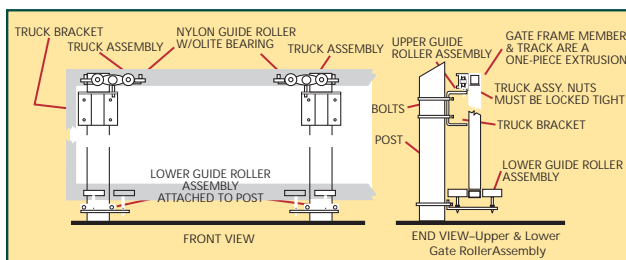

The Gate Moves. The Rollers Stay Put.

CAUTION



Gates with external rollers offer no protection for hands. Many hands are pinched, mashed and mangled in these types of gates.

We do not recommend external rollers ever.

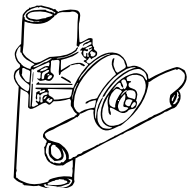

Gates should never have ground rollers. Should one of these wheels hit a small stone it could cause the gate to stop suddenly or bounce back. This could cause severe shoulder or back problems.

We do not recommend ground rollers ever.

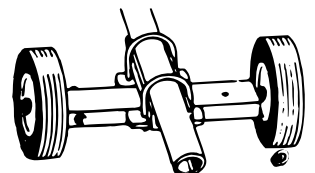

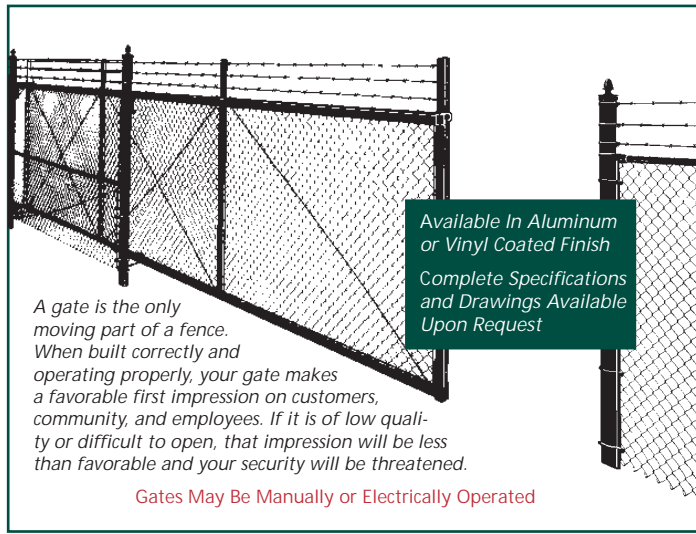

Available In Aluminum
or Vinyl Coated Finish
Complete Specifications
and Drawings Available
Upon Request

A gate is the only moving part of a fence. When built correctly and operating properly, your gate makes a favorable first impression on customers, community, and employees. If it is of low quality or difficult to open, that impression will be less than favorable and your security will be threatened.

Gates May Be Manually or Electrically Operated

Don't be fooled by copycat gates that look similar. That's where the similarity ends. Anchor Gates work every time. We guarantee it.

- Note how the vertical member of the gate is securely welded to the one-piece track frame member. The track cannot get out of alignment.
- Bolted or riveted frames will not be this strong.
- Factory lubricated and sealed roller bearings enclosed in the one-piece track frame member provide practically maintenance free performance.
- Rollers are inside a one-piece enclosed track and frame extrusion. This eliminates ice-snow-dirt-sand and similar problems.



- The Anchor truck assembly, using factory sealed and permanently lubricated roller bearings, is the only truck assembly designed to evenly distribute the forces equally to all wheels and the track, avoiding premature wear of the track or wheels.
- The Anchor gate is fabricated by trained technicians with full factory control (over 30 years experience).
- Anchor's method of attaching the fabric to the frame is the most secure means available. This procedure also helps add rigidity to the frame.
- Track is an integral part of the frame. There are no rivets or bolts to come loose.
- Anchor's gates require no ground rollers for any gate up to a 50 ft. single or a 100 ft. double opening.
- Anchor's adjustable 3/8" truss rods regulate the forces of the gate. Unlike welded bars that cannot be adjusted or cables that stretch, the Anchor truss rod will require less maintenance.

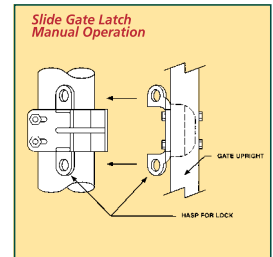
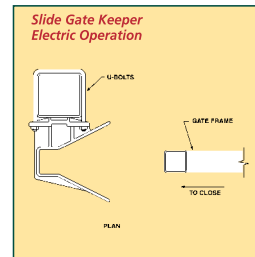

Anchor Has A Frame Design For Every Size Opening

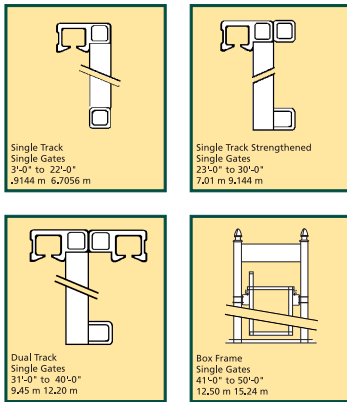

Anchor Cantilever Slide Gates:

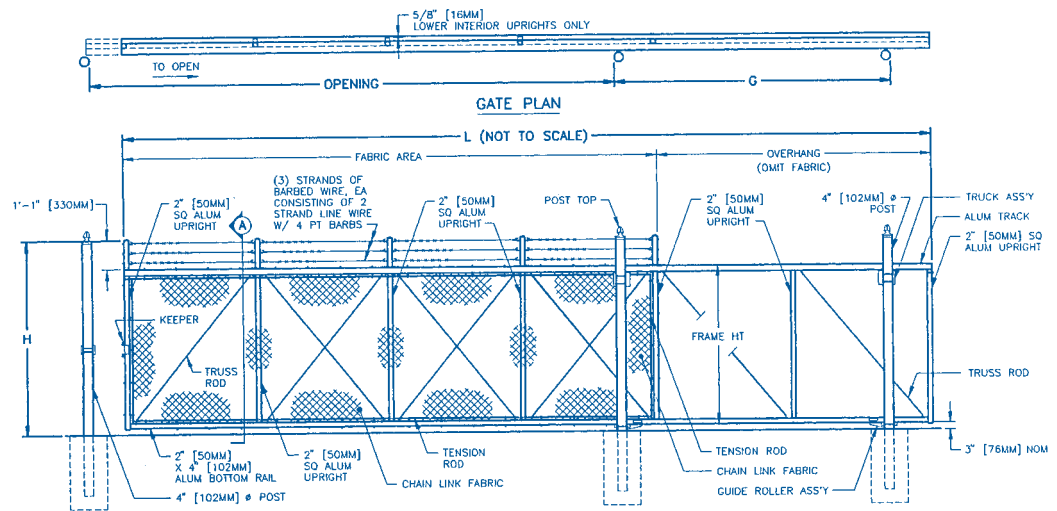

Gate Elevation - (4) Bays Shown

A combination of any 2 single gates can make a double gate. LARGER DESIGNS UPON REQUEST.

The Choice is Yours... ANCHOR'S easy to slide gate OR this back breaker.



The Better Way To Build Your Swing Gates...



Anchor Square Frame Gate swings even, year after year.



Anchor also builds many styles of Swing Gates... Pictures tell the story... Compare features and benefits of Anchor's square frame gate to an ordinary pipe frame gate.

ANCHOR SWING GATES... The BEST Choice for Over 100 Years

A gate is the most important element of any fencing job and is subject to constant punishment. A swing gate must provide the same level of security as the rest of the fence. Anchor's Swing Gates give you security and unparalleled attractiveness.

Anchor's designers recognize the need for strong, secure, and appealing gates. Through research and testing, we developed the strong Anchor Square Frame gate.

The 2-inch square tubing frame provides rigidity and freedom from sagging, and offers quick locking alignment from inside or outside. Anchor's offset hinge design allows the gate to swing through a 180-degree arc, providing complete access.

Anchor has engineered the most rugged, easy to operate gate latching combinations. Anchor's latch provides complete security when closed and locked.



After just a few years ordinary round frame gates sag or swing uneven, causing problems every time you open or close the gate.



Anchor Swing Gates:

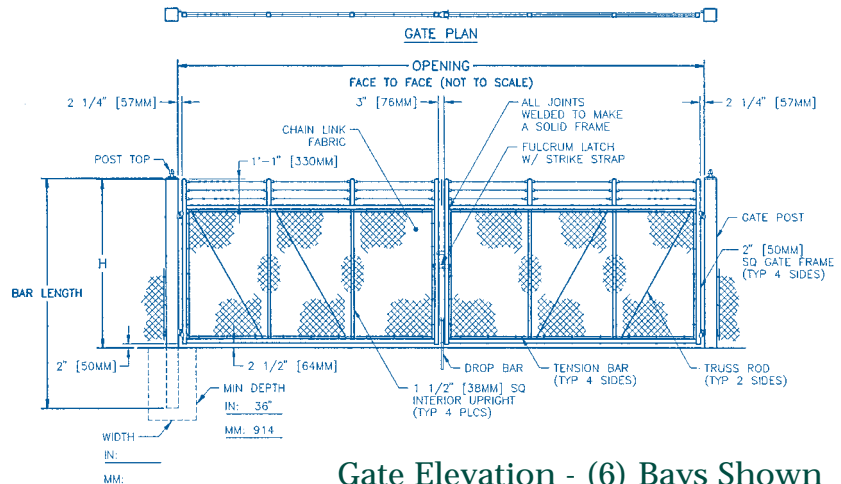

For certain applications you may consider

An Inside Look at How They Work:

PRE-HUNG Pedestrian Gates.

PRE-HUNG

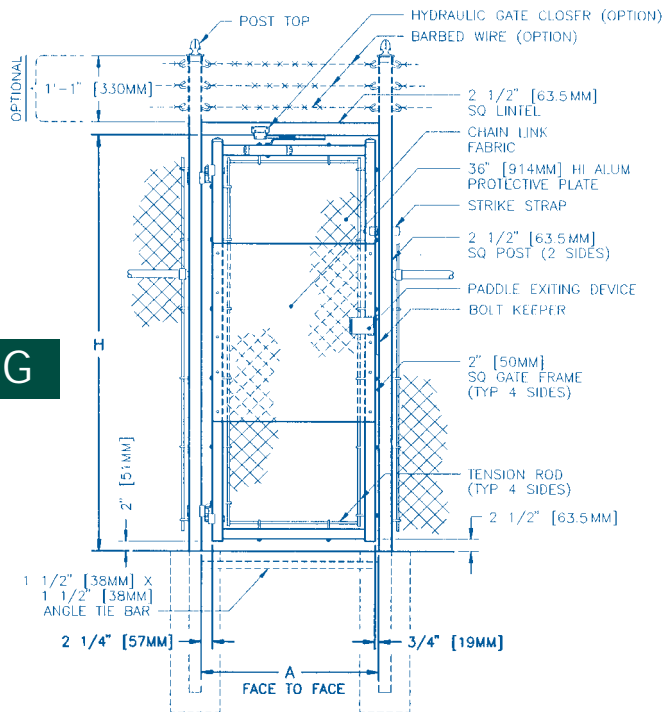

GATE ELEVATION

Frame

Anchor square frame gates feature a welded union of horizontal and vertical members. Anchor's method of fastening fabric to the frame of the gate is stronger and more attractive.

Security Drop Bar

Anchor innovation provides extra security. Drop bar cannot be lifted when both gate leaves are closed.

Square Post Hinge

Anchor's unique method of securing the hinge to the post assures longer service life and proper alignment. The hinge cannot slip on the post.

2 1/2, 3, 4, 6, 8 or 10"

Hinge Round Posts

Anchor's round post hinges are available in 2 1/2, 3, 4, 6 5/8, and 8 5/8" OD posts.

Top View Side View

Single Gate Latch

Fulcrum lever made of 5/16" thick steel, holds gate in closed position. (Pad lockable from both sides.)

Side View Top View

Double Gate Latch

Anchor's 5/16" steel double gate latch provides heavy-duty security, holding both gates closed. (Pad lockable from both sides.)

Side View Top View

Gate Hold Back

Provides secure method of holding gate in open position. Prevents accidental closing of gate.

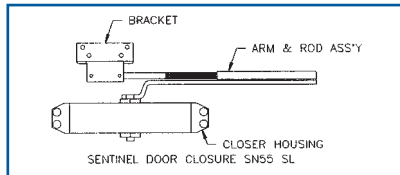

Hydraulic Gate Closer

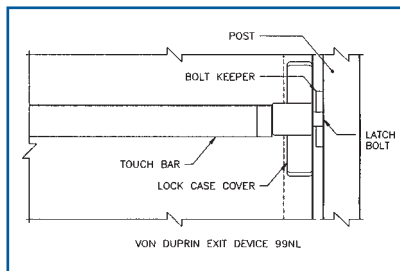

Panic Bar Exiting Device

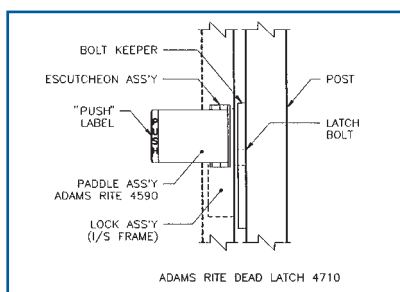

Paddle Exiting Device

OPTIONS

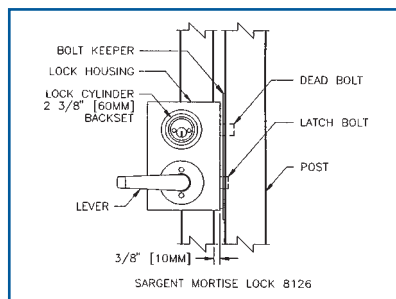

Mortise Lock With Dead Bolt

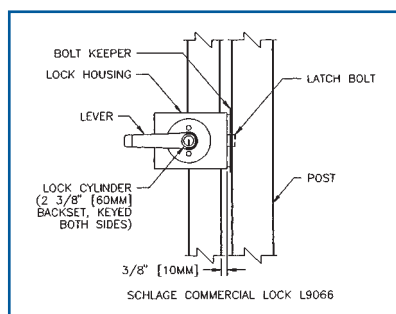

Mortise Lock

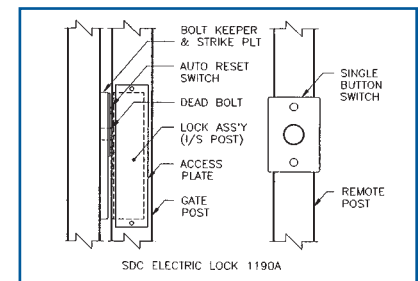

Electric Lock with Dead Bolt & Remote Switch

A Total Systems Approach To Security

Due to the ever present threat of vandalism and theft, and a dramatic increase in terrorist activities in recent years, there has never been a greater need for comprehensive security systems. That is why Anchor, a leader in the Gate Operator Industry for years, offers a complete line of products to provide a "Total Systems Approach" for your security needs.

Our "Total Systems Approach" to perimeter and facility access control is based on the integration of quality components, including fencing, gates, electric gate operators, anti-terrorist crash barriers, and telephone access systems, card readers, and more. Anchor combines these components into the most effective security system your money can buy. Best of all your access control and perimeter protection systems are designed to fit the specific needs of your facility.

Perimeter and Facility Access Control

Government buildings, military bases, airports, freight terminals, education facilities, and commercial complexes all need a "Total Systems Approach" for monitoring and access control. Anchor offers security consulting services, system design and specification writing to insure an access control system which fits your specific needs.

Access Control Equipment

We offer a full line of:

- traffic control gates
- slide and swing gates
- electric gate operators
- parking arm gates
- turnstiles
- card reader systems

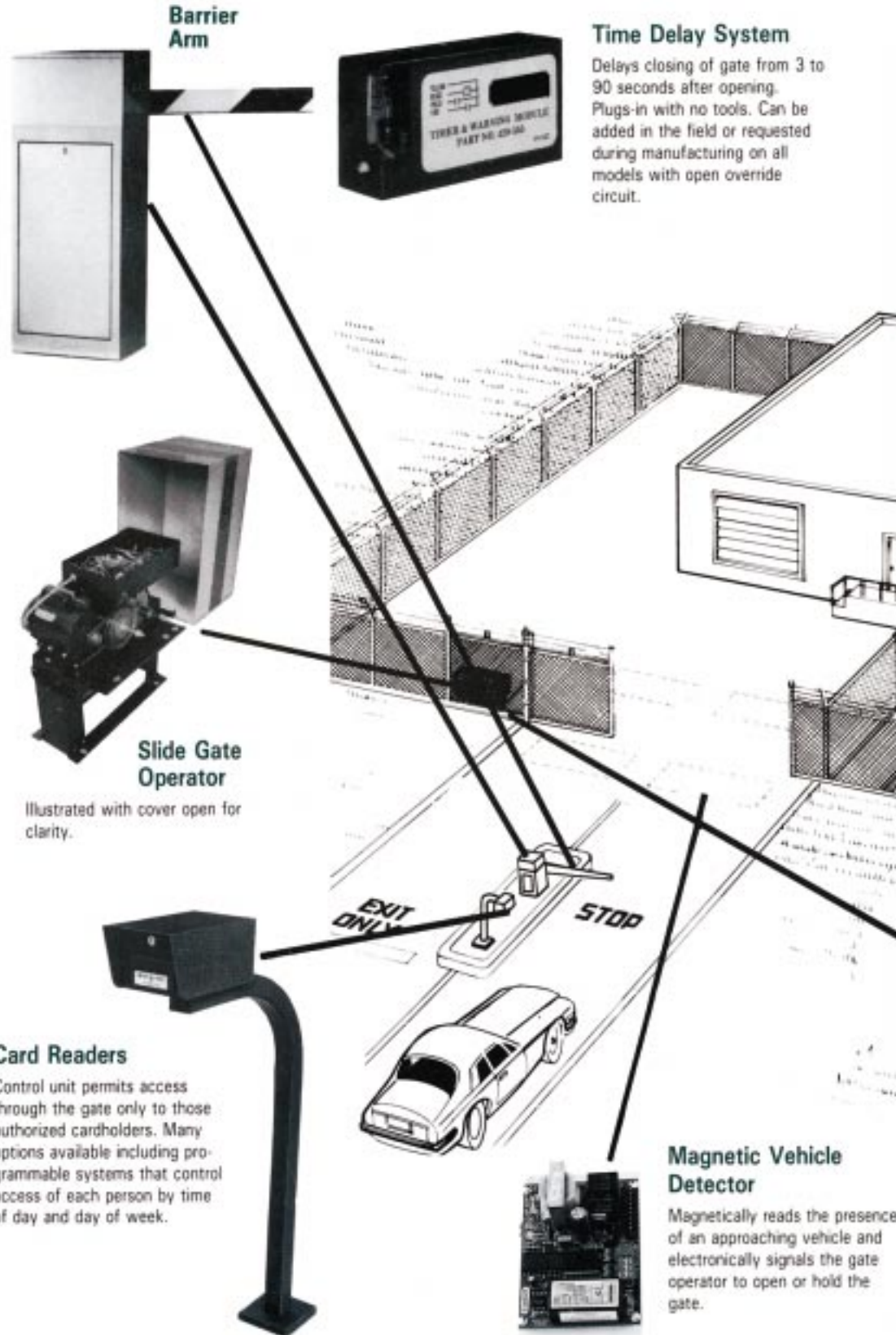



Digital Keyless Entry Plus
Allows access only to those who know the code. Provides 10,000 possible codes.



Swing Gate Operator
Illustrated with cover removed for clarity.



Telephone Entry Systems
A telephone entry system installed at the entrance can connect with one or many telephones inside the building, thru ordinary telephone lines. Available with or without directory.



Intercom
Offering the convenience and security of point-to-point intercommunication, our complete system includes the outdoor call station on a gooseneck stand, a bell push-button, bell signal, and indoor call station.

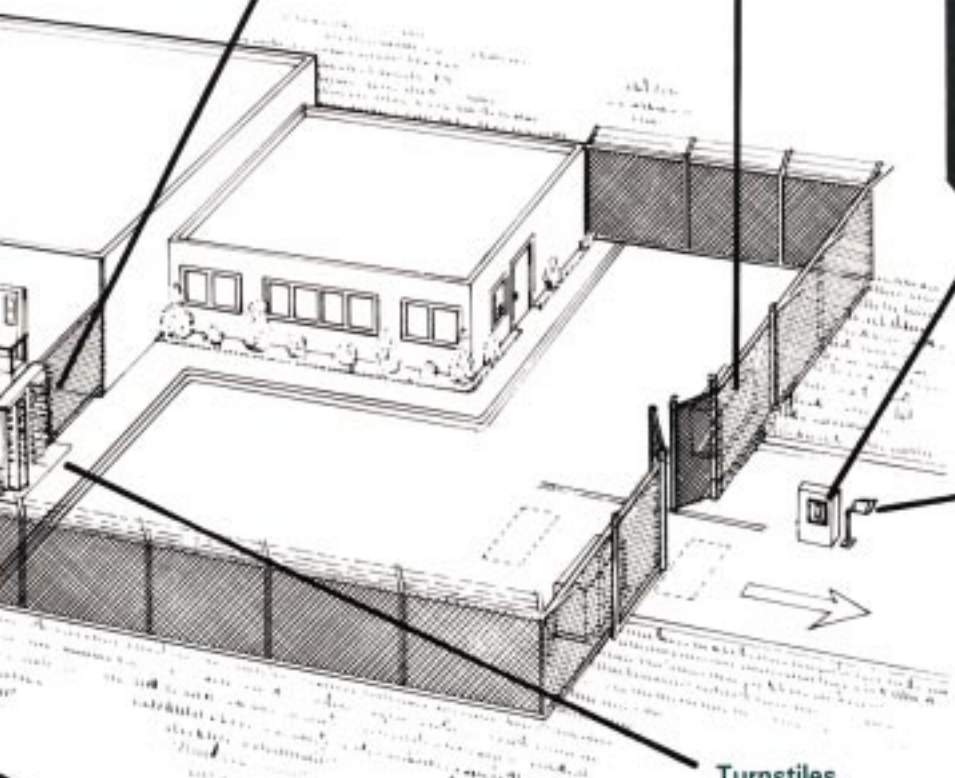

Turnstiles



One-Channel Transmitter, Two-Channel Transmitter or Four-Channel Transmitter
The two and four-channel transmitters feature completely independent code settings offering the convenience of controlling two or four separate receivers from one transmitter.

Today, security means more than a strong fence and a locked gate. Let Anchor, a leader in the Gate Operator and Perimeter Access Industry provide you with the "Total Systems Approach." Our experienced Sales, Engineering and Service Departments can provide you with design assistance, training seminars, and technical support in perimeter access security systems that are as individual as your needs.

When There's No Room To Swing or Slide A Gate, Consider Anchor's Vertical Lift Gate.

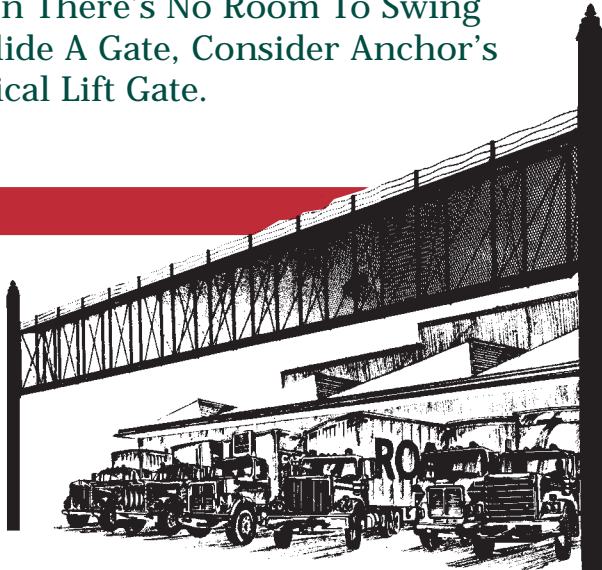

Anchor is the nation's leading designer and manufacturer of work-designed gates. We can

custom engineer a gate in almost any width, for almost any location, or for any purpose.

- Anchor's Vertical Lift Gate is the most secure gate on the market today.
- Anchor builds it right the first time, every time.
- Every good product will be imitated by others. Anchor's Vertical Lift Gate is no exception to this rule. Be aware that imitations will not work as well as the Anchor Vertical Lift Gate.
- Anchor Vertical Lift Gates are not affected by ice or snow build-up.
- Anchor Vertical Lift Gates open and close faster than other gates.

e.g.: a conventional slide or swing gate opens at a maximum rate of 1 foot per second. It takes the same amount of time to close. It is, therefore, easy to see that a 30 foot opening gate will take 30 seconds to open and 30 seconds to close. In all, that's 60 seconds.

The Anchor Vertical Lift Gate takes 14 seconds to open and 14 seconds to close no matter how large the opening is, even a 100 foot opening. This is a total of 28 seconds, or less than one-half the time of the conventional gate. This means that the gate is open only one-half as long. No gate is more dependable or more secure than an Anchor Vertical Lift Gate.

Overhead Slide Gate

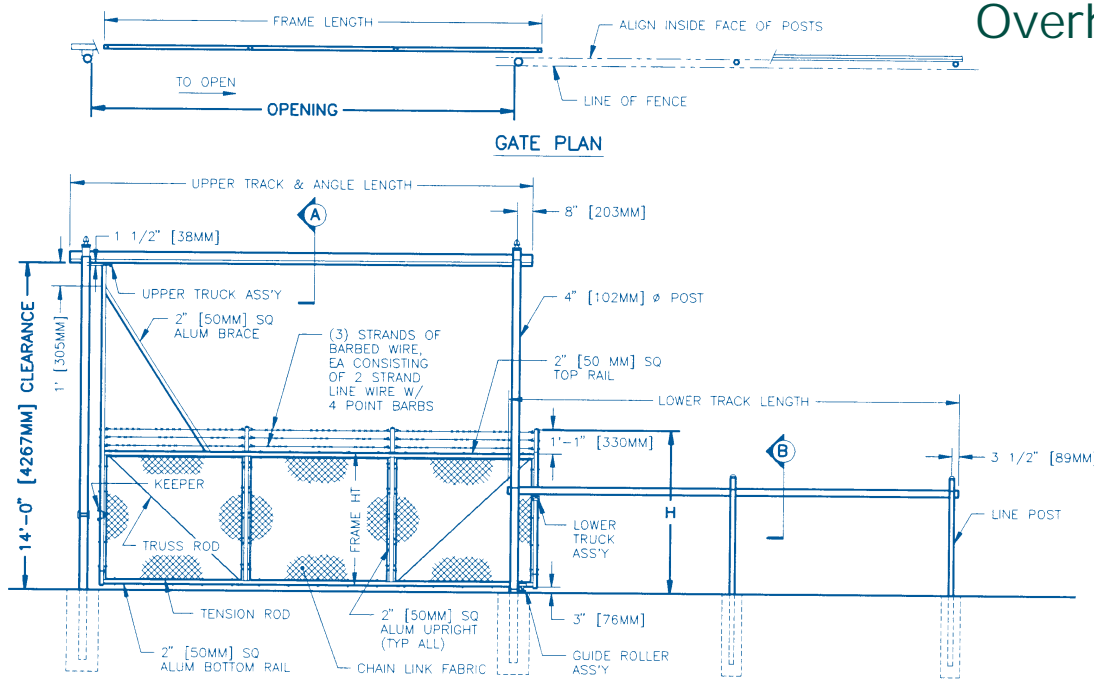

Gate Elevation - (3) Bays Shown



For more information, contact our Customer Service Department:
 1-888-MH-FENCE (toll-free)
 P.O. Box 365, La Habra, CA 90633
 e-mail: info@mhfence.com • www.mhfence.com

Anchor Fence Products available from:

