



RESIDENTIAL ORNAMENTAL IRON FENCE SYSTEMS





Master Halco's Classic Premier™ Residential Ornamental fencing provides the classic look of traditional ornamental iron with a level of quality and durability that is truly premier in the industry. Constructed of galvanized steel and coated with a state-of-the-art, mar-resistant polyester powder-coat finish, this fencing offers strength, durability and corrosion resistance in an attractive and virtually maintenance-free fence. Engineered to maximize strength, the special shape of our Classic Premier rail is two to three times stronger than many other fence systems.

The design possibilities are staggering! Choose from six attractive styles in four colors: black, white, bronze and desert sand. Classic Premier fence panels can rack to conform to a slope. And 8' sections instead of 6' sections mean fewer posts to set.

Classic Premier is designed with ease of handling and installation in mind. Panels are supplied unassembled to avoid damage during shipping. Panel assembly is accomplished by a unique fastening system contained within the fence rails. Installation is performed entirely with bolts, not welding, so that the integrity of the four-step coating is not compromised. Classic Premier Residential comes with a 12-year limited warranty* backed by Master Halco, one of the largest distributors and manufacturers of fencing materials in the world.

Assembled panels are available upon special request. Contact your nearest Master Halco branch service center for pricing and availability.

*See actual warranty for details.

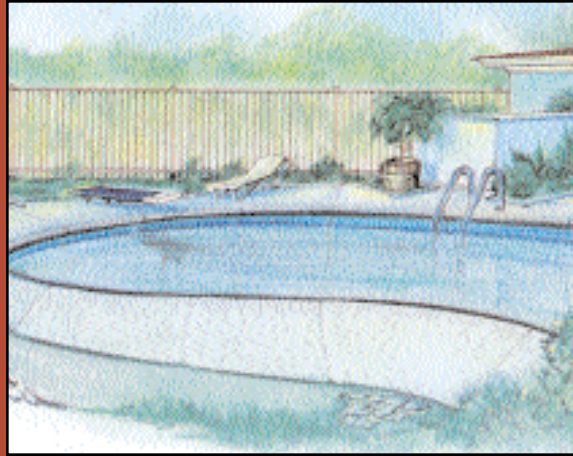

UNIVERSAL

Simple, clean lines.
A wonderful addition to landscaping, ideal around the swimming pool.

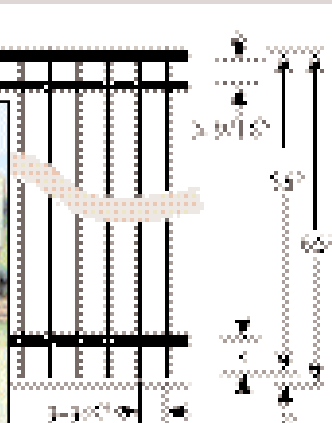

UNIVERSAL 3-RAIL

The double top rail gives the perfect accent to almost any residential or light commercial application.

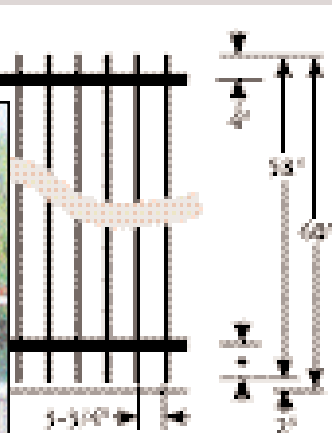

PICKET

The look of an old-fashioned wrought iron fence.
Add heavy-duty molded plastic spear points to the tops of the pickets for a distinctive, old-world look.

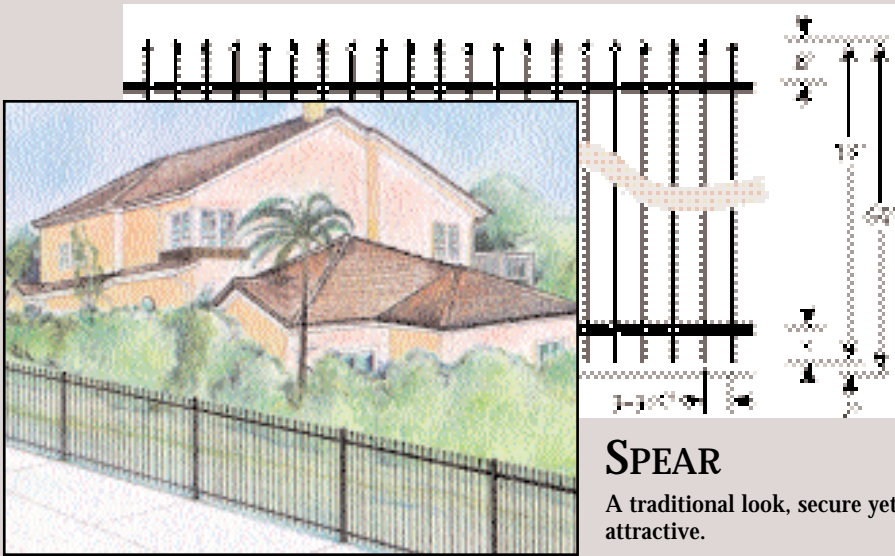

SPEAR

A traditional look, secure yet attractive.

Available in the following colors:

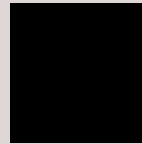

Black

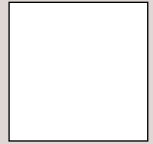

White

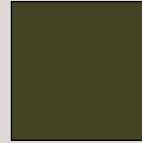

Bronze

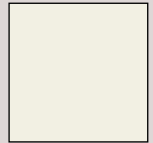

Desert Sand

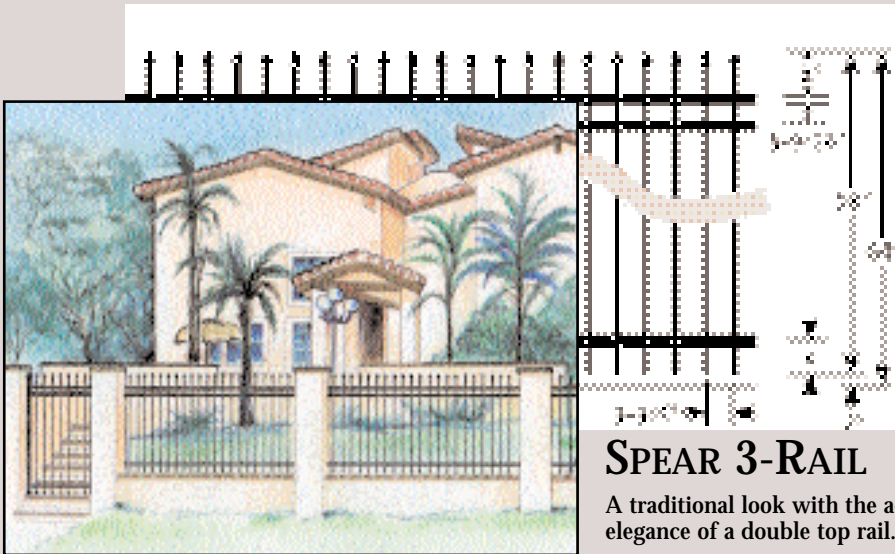

SPEAR 3-RAIL

A traditional look with the added elegance of a double top rail. Attractive and effective.

Available in the following heights:

4' high fence

5' high fence

6' high fence

NOTE: Universal style available in 4' and 5' high fence only.

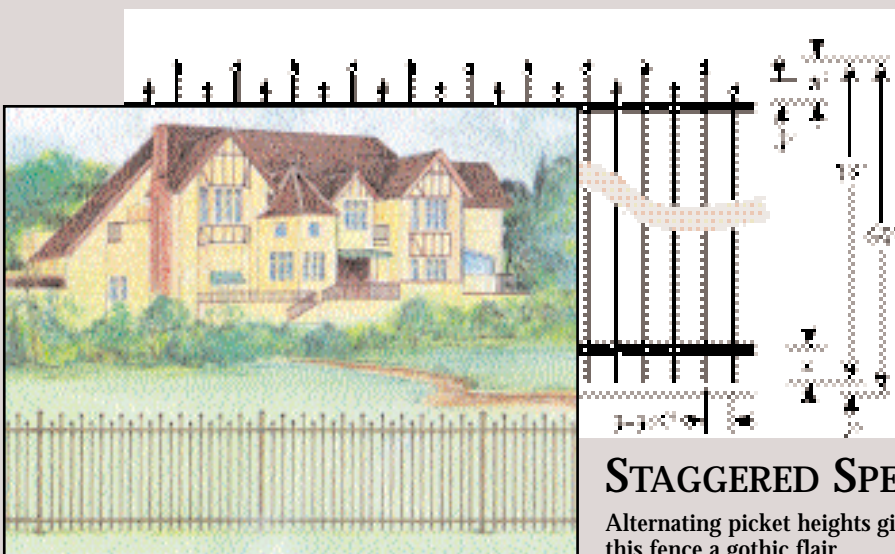

STAGGERED SPEAR

Alternating picket heights give this fence a gothic flair.

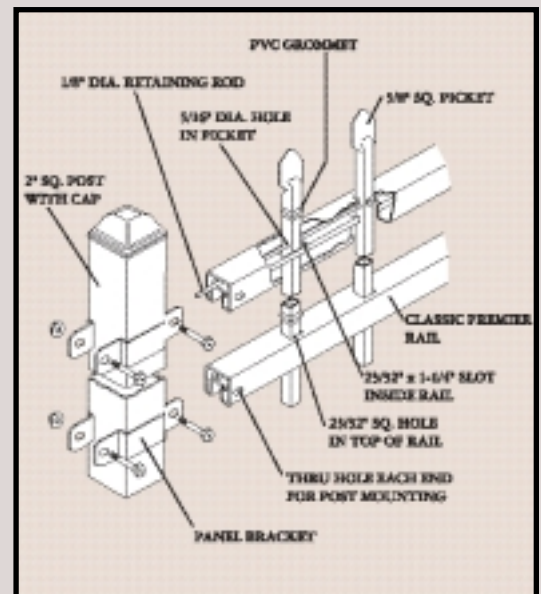

Detail Illustration

• Dimension varies depending on the height and style of fence chosen.



SALT SPRAY TEST - ASTM B117
Independent Test Lab Results:

Each of the specimens were scribed (ASTM D1654) with a cut through the coating to the bare metal. The specimens were then exposed to a 5% salt spray (ASTM B117) and evaluated periodically for degree of rusting and/or any change in the coating.

Specimen A was removed after 100 hours. Specimens B and C were removed after 200 hours. These three specimens showed the following results:

Specimens A, B and C - each of these specimens showed similar failure, the coating softened and blistered extensively and there was rust along the

scribe line. When the specimens were scraped, the coating along the scribe line and on the blistered areas was easily removed. The creepage rating was a "0" for loss of coating (worst possible rating).

Specimen D was removed after 300 hours. The results were as follows:

Specimen D - No rust and absolutely no coating removed! The specimen was in a condition similar to when it was first exposed to the salt spray, even after scraping! Classic Premier Residential Ornamental received the best possible rating, "10"!

REFERENCE TO CORROSION CREEPAGE SPECIMENS TESTED PER ASTM B117

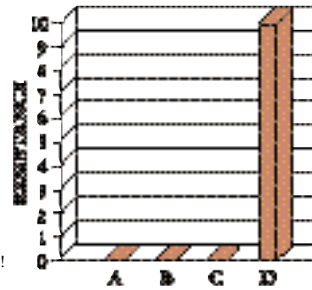

12-YEAR LIMITED WARRANTY

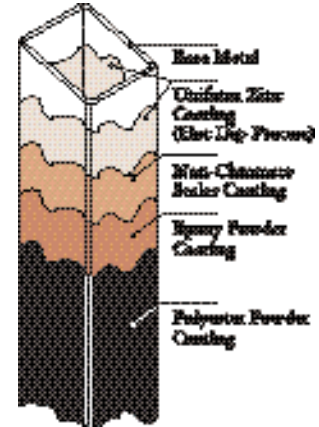
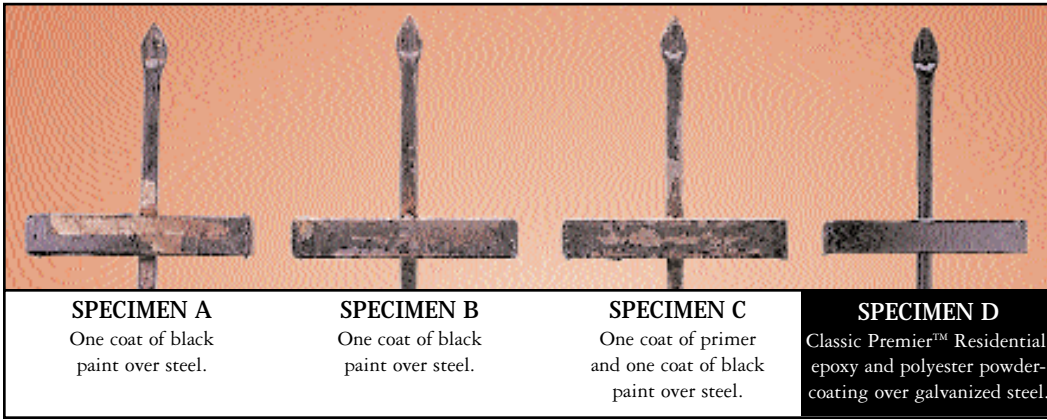

Classic Premier™ Residential 4-Step Coating

SPECIFICATIONS
Section 02830

Ornamental Iron Fencing

1.01 Work Included

The contractor shall provide all labor, materials and accessory items necessary for the installation of the ornamental metal fence system defined herein at (specify project location).

1.02 Related Work

Section 022 __ Earthwork
Section 030 __ Concrete

1.03 System Description

The manufacturer shall supply a total ornamental fencing system of the design, style, strength and picket spacing defined herein. The system shall include all components: pickets, rails, posts, gates and hardware as required.

1.04 Quality Assurance

The contractor shall provide laborers and supervisors who are thoroughly familiar with the type of construction involved and the materials and techniques specified.

1.05 References

ASTM A513 - Standard Specifications for Electric-Resistance-Welded Carbon and Alloy Steel Mechanical Tubing.

ASTM A526 - Specifications for Steel Sheet, Zinc-Coated (Galvanized) by the Hot-Dip Process.

ASTM B117 - Standard Test Method of Salt Spray (Fog) Testing.

ASTM D1654 - Evaluation of Painted or Coated Specimens Subjected to Corrosive Environments.

1.06 Submittals

Product literature and warranty shall be submitted prior to installation to confirm compliance with the requirements for the materials specified in this section.

1.07 Product Handling and Storage

Upon receipt at the jobsite all materials shall be inspected to ensure that no damage has occurred during shipping. Materials shall be stored in such a manner as to preclude damage, vandalism and theft.

2.01 Supplier

The ornamental metal fencing system shall conform to Master Halco Classic Premier™ Ornamental _____ style (specify style from options in current Classic Premier™ Ornamental literature).

2.02 Materials

A. All primary fence components; pickets, rails and posts shall be manufactured from coil steel having a yield strength of 45,000 psi.

B. All primary fence components; pickets, rails and posts shall be galvanized by the hot dip process to meet the requirements of ASTM A526 and shall have a minimum zinc coating thickness of .60 oz/sq. ft. (coating designation G-60).

C. Pickets shall be 5/8" sq. 18 ga., cold rolled steel tubing manufactured per ASTM A513.

D. Rails shall be made of 16 ga., cold rolled steel. The cross-sectional shape of the rails shall conform to the manufacturer's Classic Premier rail design. The cross-sectional outside dimensions of the rails shall be 1-1/4" sq. Each rail shall have a minimum weight of 1.33 pounds per square foot.

E. Posts shall be 2" sq., 16 ga., cold rolled steel tubing manufactured per ASTM A513.

2.03 Finish

A. Galvanized steel fence components shall be subjected to a six-stage wash and pre-treatment system which includes zinc phosphate and non-chromate sealer.

B. Galvanized steel fence components shall then receive a two-step powder coating applied by the electrostatic spray process. The base coat shall be a thermosetting epoxy powder coating with a minimum coating thickness of 2-4 mils. The top coat shall be a mar-resistant TGIC polyester powder coating with a minimum coating thickness of 2-4 mils.

C. Color shall be _____ (select option from current Classic Premier™ Ornamental literature).

D. Coated galvanized steel fence components shall be capable of withstanding 3500 hours of salt spray testing, without loss of adhesion, as specified in ASTM B117.

2.04 Fabrication

A. Pickets, rails and posts shall be cut to specified lengths. Rails shall be punched to accept pickets. Pickets shall be drilled to accept retaining rods. Cutting, punching and drilling shall be done prior to coating to facilitate assembly without compromising the integrity of the finish.

B. PVC grommets shall be inserted into the pre-punched holes in the rails. Pickets shall be inserted through the grommets so that the pre-drilled holes in the pickets align with the internal upper raceway of the rails.

C. A 1/8" diameter galvanized steel retaining rod shall then be inserted into the upper raceway of the rails through the pre-drilled holes in each picket.

D. Completed sections shall be capable of supporting a 250 pound load at mid-span without permanent deformation. Completed sections can rack up to 36" in 8' section (22°).

E. Posts shall have a square cap firmly affixed to the extending end.

F. Gates shall be fabricated using the same materials as for the complete fencing system, and gate framework shall have the same cross-sectional dimensions as the panel rails.

2.05 Warranty

A. The ornamental metal fence system shall include a written 12-year limited warranty against defects in materials and workmanship.

B. The ornamental metal fence system shall include a written 12-year limited warranty on the coating against cracking, chipping, blistering, peeling or corroding.

3.01 Preparation

All new installations shall be laid out by the contractor in accordance with the construction plans.

3.02 Installation

A. Set fence posts at 97-5/8" on center ± 1/2". Set gate posts for gate opening specified in the construction drawings. Posts shall be placed a minimum of 18" into the ground and set in concrete.

B. Attach fabricated panels to posts using brackets supplied by the manufacturer.

C. Install gates by attaching hardware supplied by the manufacturer.

3.03 Cleaning

Contractor shall clean the jobsite of construction debris.

Specifications subject to change without notice.



For more information, contact our Customer Service Department:
1-888-MH-FENCE (toll-free)
110 E. La Habra Blvd., La Habra, CA 90631
e-mail: info@fenceonline.com • www.fenceonline.com